

## General Description

The Skytop SM2217-MTBD is a complete GPS/BeiDou engine module that features super sensitivity, ultra low power and small form factor. The GPS/BeiDou signal is applied to the antenna input of module, and a complete serial data message with position, velocity and time information is presented at the serial interface with NMEA protocol or custom protocol.

Its  $-165\text{dBm}$  tracking sensitivity extends positioning coverage into place like urban canyons and dense foliage environment where the GPS/BeiDou was not possible before. The small form factor and low power consumption make the module easy to integrate into portable device like PNDs, mobile phones, cameras and vehicle navigation systems

## Applications

- LBS (Location Based Service)
- PND (Portable Navigation Device)
- Vehicle navigation system
- Mobile phone



Figure 1: SM2217-MTBD Top View

## Features

- Build on high performance, low-power MT3333 chipset
- Ultra high sensitivity:  $-165\text{dBm}$
- Extremely fast TTFF at low signal level
- Built in high gain LNA
- Low power consumption: Max  $35\text{mA}@3.3\text{V}$
- NMEA-0183 compliant protocol or custom protocol
- Operating voltage:  $2.8\text{V}$  to  $4.3\text{V}$
- Operating temperature range:  $-40$  to  $85^\circ\text{C}$
- SMD type with stamp holes
- Small form factor:  $22.4 \times 17 \times 3.0\text{mm}$
- RoHS compliant (Lead-free)

## Performance Specification

Parameter	Specification
Receiver Type	Gps/Glonass/Galileo/Beidou(afterICDreleased)receiver Supports multi-GNSS incl.QZSS,SBAS ranging Supports:WAAS/EGNOS/MSAS/GAGAN
Sensitivity	Tracking -165dBm Acquisition -163dBm(hot) -148dBm(cold)
Accuracy	Position 5m CEP without SA Velocity 0.1m/s without SA Timing (PPS) 10ns RMS
Acquisition Time	Cold Start 38s Warm Start 35s Hot Start 1s Re-Acquisition <1s
Power Consumption	Tracking 35mA @3.3V Vcc Acquisition 35mA Sleep/Standby TBD
NavigationDataUpdate Rate	1Hz
Operational Limits	Altitude Max 18,000m Velocity Max 515m/s Acceleration Less than 4g

## Interfaces Configuration

**Power Supply:** Regulated power for the SM2217-MTBD is required. The input voltage Vcc should be 3.3V  $\pm$ 10%, maximum, current is no less than 35mA. Suitable decoupling must be provided by external decoupling circuitry.

**Antenna:** The SM2217-MTBD GPS/BeiDou receiver is designed for supporting the active antenna or passive antenna connected with pin RF\_IN. The gain of active antenna should be no less than 15dB. The maximum noise figure should be no more than 2.5dB and output

impedance is at 50 Ohm.

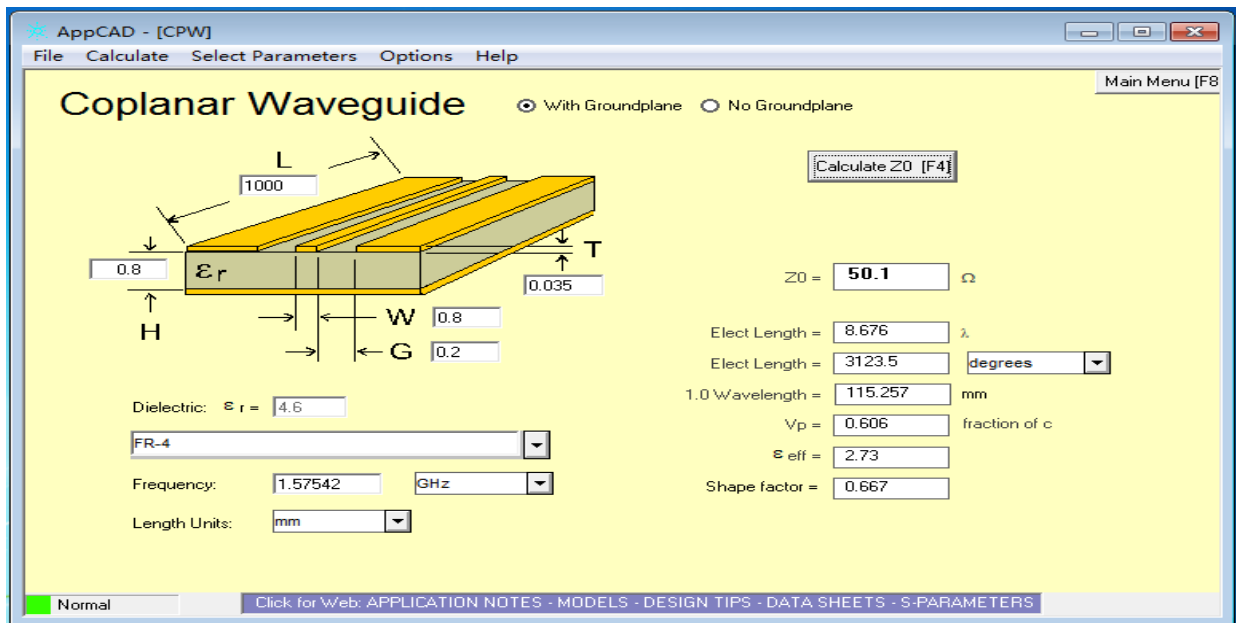

**UART Ports:** The module supports two full duplex serial channels UART . All serial connections are at 3V CMOS logic levels, if need different voltage levels, use appropriate level shifters. The baud rate of both serial ports are fully programmable, the data format is however fixed: X, N, 8, 1, i.e. X baud rate, no parity, eight data bits and one stop bit, no other data formats are supported, LSB is sent first. The modules default baud rate is set up 9600bps, however, the user can change the default baud rate to any value from 4800 bps to 115kbps. UART is used e.g. for booting and NMEA interface.

### AntennaSupervisor:

```

ANTSTATUS=OK( Active antenna connected and powered)
$GPTXT,01,01,02,ANTSTATUS=OK*3B;
ANTSTATUS=SHORT( Antenna short)
$GPTXT,01,01,02,ANTSTATUS=SHORT*6D;
ANTSTATUS=OPEN( Antenna not connected or antenna defective)
$GPTXT,01,01,02,ANTSTATUS=OPEN*2B;

```

**Backup Battery Power:** In case of a power failure on pin Vcc, real-time clock and backup RAM are supplied through pin VBAT. This enables the SM2217-MTBD GPS /BeiDou Receiver to recover from power failure with either a hot start or a warm start (depending on the duration of Vcc outage). If no Backup Battery is connected, the receiver performs a cold start upon

powered up.

## Pin Description

Pin No.	Pin name	I/O	Description	Remark
1	NC		NoConnection	Leave open
2	NC		NoConnection	Leave open
3	TXA	O	UARTSerialDataOutput 0	Leave Open in not used
4	RXA	I	UARTSerialDataInput 0	Pull up if not used
5	NC		NoConnection	Leave Open in not used
6	V_IN	I	ModulePowerSupply	
7	GND	G	Ground	
8	VDD3.0OUT	O	3.0Vsupply output	Leave Open in not used
9	GPIO1	I/O	2.8V,LVTTL I/O PPU, PPD, SMT2mA~16mA PDR JTAG interface clock Default:75Kpull-down Default: 8mA driving	
10	Reset	I	Module Reset	Leave Open in not used
11	V_BAT	I	RTCBattery Input	Leave Open in not used
12	NC		NoConnection	Leave open
13	GND	G	Ground	
14	GND	G	Ground	

15	GND	G	Ground	
16	RF_IN	I	GPS&BeiDouAntenna Input	
17	GND	G	Ground	
18	Vcc_3.0V	O	Voltage Output for Active AntennaMaybe connected to V_ANT Leave open if not used	
19	V_ANT	I	Active Antenna External Voltage Supply	
20	GPIO2	I/O	2.8V,LVTTL I/O PPU, PPD, SMT2mA~16mA PDR JTAG interface clockDefault:75K pull-down Default: 8mA driving	
21	NC		NoConnection	Leave open
22	NC		NoConnection	Leave open
23	NC		NoConnection	Leave open
24	NC		NoConnection	Leave open
25	NC		NoConnection	Leave open
26	NC		NoConnection	Leave open
27	NC		NoConnection	Leave open
28	PPS	O	Timepulse Signal	Leave Open in not used

### Pin Assignment

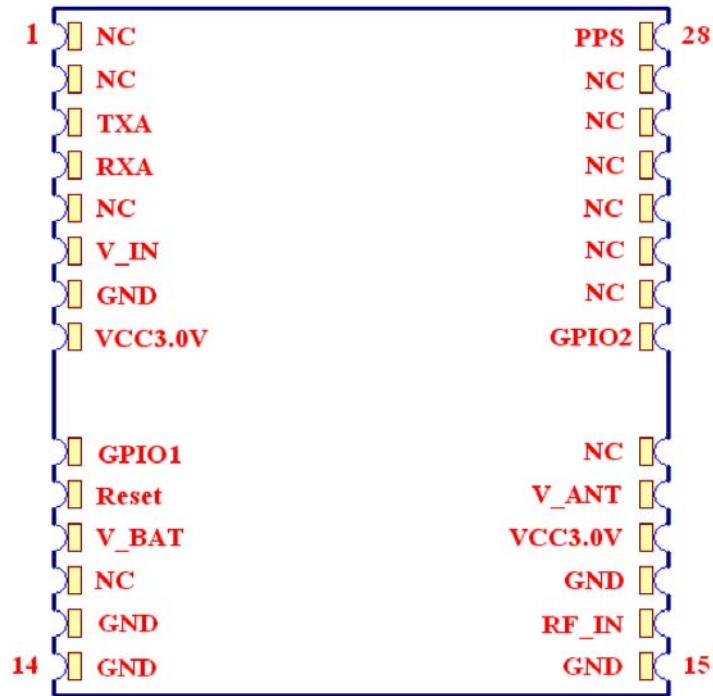

Figure 2: SM2217-MTBD Pin Package

### Mechanical Specification

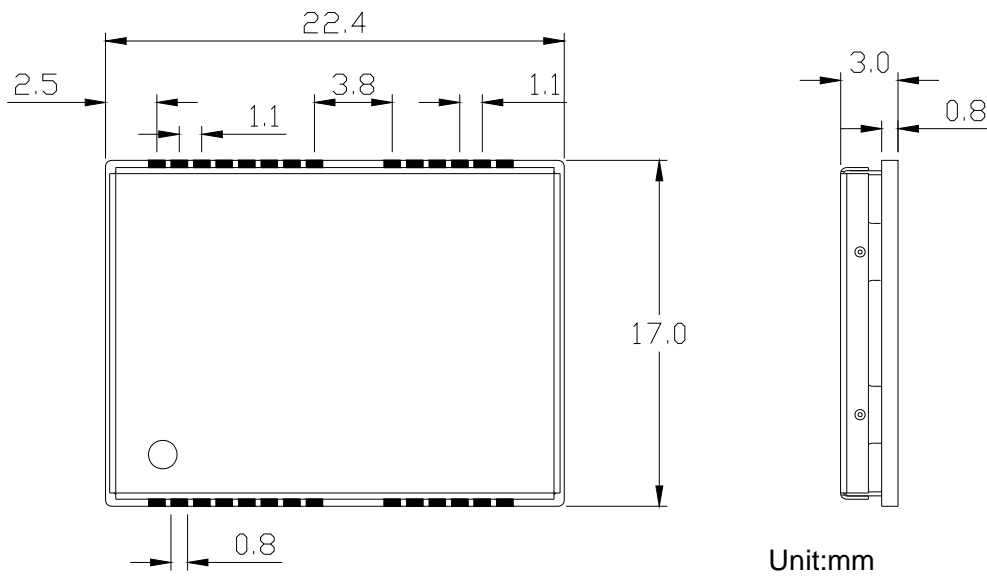

Figure 3: SM2217-MTBD Dimensions

## Electrical Characteristics

### Absolute Maximum Rating

Parameter	Symbol	Min	Max	Units
Power Supply				
Power Supply Volt.	Vcc	2.8	4.3	V
Input Pins				
Input Pin Voltage I/O	RXD/TXD	-0.3	3.6	V
Backup Battery	VBAT	2.0	3.6	V
Environment				
Storage Temperature	Tstg	-40	125	°C
PeakReflow Soldering Temperature	Tpeak		260	°C
Humidity			95	%

Note: Absolute maximum ratings are stress ratings only, and functional operation at the maxims is not guaranteed. Stress beyond the limits specified in this table may affect device reliability or cause permanent damage to the device. For functional operating conditions, refer to the operating conditions tables as follow.

### Operating Conditions

Parameter	Symbol	Condition	Min	Typ	Max	Units
Power supply voltage	Vcc		2.8	3.3	4.3	V
Powersupplyvoltagegeripple	Vcc_PP	Vcc=3.0V			30	mV

Consumption current	I <sub>CC</sub>	V <sub>CC</sub> =3.0V		35	35	mA
Input high voltage	V <sub>IH</sub>		0.7xV <sub>CC</sub>		V <sub>CC</sub> +1.0	V
Input low voltage	V <sub>IL</sub>		-0.3		0.3xV <sub>CC</sub>	V
Output high voltage	V <sub>OH</sub>		0.8xV <sub>CC</sub>		V <sub>CC</sub>	V
Output low voltage	V <sub>OL</sub>		0		0.2xV <sub>CC</sub>	V
Operating temperature	T <sub>opr</sub>		-40		85	°C

## Software Protocol

### NMEA 0183 Protocol

The NMEA protocol is an ASCII-based protocol, Records start with a \$ and with carriage return/line feed. GPS&BeiDou specific messages all start with \$GPxxx/GNxxx/BDxxx where xxx is a three-letter identifier of the message data that follows. NMEA messages have a checksum, which allows detection of corrupted data transfers.

The skytop SM2217-MTBD supports the following NMEA-0183 messages: GGA. RMC.GSA.GLL.GSV.VTG

**Table 1: NMEA-0183 Output Messages**

NMEA Record	DESCRIPTION
BD only mode NMEAOutPut: <b>BDRMC.BDGGA.BDGSV.BDGSA.BDGLL.BDVTG</b>	
GPS only mode NMEAOutPut: <b>GPRMC.GPGGA.GPGSV.GPGSA.GPGLL.GPVTG</b>	
GPS+BDonlymode NMEAOutPut: <b>GNRMC.GNGGA.GPGSV.BDGSV.GPGSA.BDGSA.GPGLL.GPVTG</b>	
xxGGA	Global positioning system fixed data
xxGLL	Geographic position—latitude/longitude
xxGSA	GNSS DOP and active satellites

xxGSV	GNSS satellites in view
xxRMC	Recommended minimum specific GNSS data
xxVTG	Course over ground and ground speed

## GGA-Global Positioning System Fixed Data

Table 2 contains the values of the following example:

\$xxGGA, 161229.487,3723.2475,N, 12158.3416,W, 1,07,1.0,9.0,M.0000\*18

**Table 2: GGA Data Format**

Name	Example	Units	Description
Message ID	\$xxGGA		GGA protocol header
UTC Position	161229.487		hhmmss.sss
Latitude	3723.2457		ddmm.mmmm
N/S indicator	N		N=north or S=south
Longitude	12158.3416		dddmm.mmmm
E/W Indicator	W		E=east or W=west
PositionFixIndicator	1		See Table 2-1
Satellites Used	07		Range 0 to 12
HDOP	1.0		Horizontal Dilution of Precision
MSL Altitude	9.0	meters	
Units	M	meters	
Geoids Separation		meters	
Units	M	meters	
Age of Diff.Corr.		second	Null fields when DGPS is not Used
Diff.Ref.Station ID	0000		
Checksum	*18		



<CR> <LF>			End of message termination
-----------	--	--	----------------------------

**Table 2-1: Position Fix Indicators**

Value	Description
0	Fix not available or invalid
1	GPS &BDSPS Mode, fix valid
2	Differential GPS, SPS Mode, fix valid
3	GPS&BD PPS Mode, fix valid

### GLL-Geographic Position – Latitude/Longitude

Table 3 contains the values of the following example:

\$xxGLL , 3723.2475, N,12158.3416, W,161229.487, A\*2C.

**Table 3: GLL Data Format**

Name	Example	Units	Description
Message ID	\$xxGLL		GLL protocol header
Latitude	3723.2475		ddmm.mmmm
N/S Indicator	N		N=north or S=south
Longitude	12158.3416		dddmm.mmmm
E/W Indicator	W		E=east or W=west
UTC Position	161229.487		hhmmss.sss
Status	A		A=data valid or V=data not valid
Checksum	*2C		
<CR> <LF>			End of message termination

### GSA-GNSS DOP and Active Satellites

Table 4 contains the values of the following example:

\$xxGSA , A, 3, 07, 02, 26,27, 09, 04,15, , , , , , 1.8,1.0,1.5\*33.

**Table 4: GSA Data Format**

Name	Example	Units	Description
Message	\$xxGSA		GSA protocol header
Mode 1	A		See Table 4-2
Mode 2	3		See Table 4-1
Satellite Used	07		Sv on Channel 1
Satellite Used	02		Sv on Channel 2
...	...		...
Satellite Used			Sv on Channel 66
PDOP	1.8		Position Dilution of Precision
HDOP	1.0		Horizontal Dilution of Precision
VDOP	1.5		Vertical Dilution of Precision
Checksum	*33		
<CR> <LF>			End of message termination

**Table 4-1: Mode 1**

Value	Description
1	Fix not available
2	2D
3	3D

**Table 4-2: Mode 2**

Value	Description
M	Manual-forced to operate in 2D or 3D mode
A	Automatic-allowed to automatically switch 2D/3D

## GSV-GNSS Satellites in View

Table 5 contains the values of the following example:

\$xxGSV , 2, 1, 07, 07, 79,048, 42, 02, 51,062, 43, 26, 36,256, 42, 27, 27, 138,42\*71

\$xxGSV, 2, 2, 07, 09, 23,313, 42, 04, 19, 159, 41, 15,12,041, 42\*41.

**Table 5: GGA Data Format**

Name	Example	Units	Description
Message ID	\$xxGSV		GSV protocol header
Number of Message	2		Range 1 to 3
Message Number	1		Range 1 to 3
Satellites in View	07		
Satellite ID	07		Channel 1(Range 1 to 66)
Elevation	79	degrees	Channel 1(Maximum 90)
Azinmuth	048	degrees	Channel 1(True, Range 0 to 359)
SNR(C/NO)	42	dBHz	Range 0 to 99,null when not tracking
...			...
Satellite ID	27		Channel 4(Range 1 to 66)
Elevation	27	degrees	Channel 4(Maximum 90)
Azimuth	138	degrees	Channel 4(True, Range 0 to 359)
SNR(C/NO)	42	dBHz	Range 0 to 99, null when not tracking
Checksum	*71		
<CR> <LF>			End of message termination

Depending on the number of satellites tracked multiple messages of GSV data may be required.

### **RMC-Recommended Minimum Specific GNSS Data**

**Table 6 contains the values of the following example:**

\$xxRMC, 161229.487, A, 3723.2475, N, 12158.3416, W, 0.13,309.62, 120598,, \*10

**Table 6: RMC Data Format**

Name	Example	Units	Description
Message ID	\$xxRMC		RMC protocol header
UTS Position	161229.487		hhmmss.sss
Status	A		A=data valid or V=data not valid
Latitude	3723.2475		ddmm.mmmm
N/S Indicator	N		N=north or S=south
Longitude	12158.3416		dddmm.mmmm
E/W Indicator	W		E=east or W=west
Speed Over Ground	0.13	Knots	
Course Over	309.62	Degrees	True
Ground			
Date	120598		Dummy
Magnetic variation		Degrees	E=east or W=west
Checksum	*10		
<CR> <LF>			End of message termination

### VTG-Course Over Ground and Ground Speed

Table 7 contains the values of the following example:

\$xxVTG, 309.62, T, M, 0.13, N, 0.2, K\*6E

**Table 7: VTG Data Format**

Name	Example	Units	Description
Message ID	\$xxVTG		VTG protocol header
Course	309.62	Degrees	Measured heading
Reference	T		True
Course		Degrees	Measured heading

Reference	M		Magnetic
Speed	0.13	Knots	Measured horizontal speed
Units	N		Knots
Speed	0.2	Km/hr	Measured horizontal speed
Units	K		Kilometer per hour
Checksum	*6E		
<CR> <LF>			End of message termination

## Manufacturing Process Recommendations

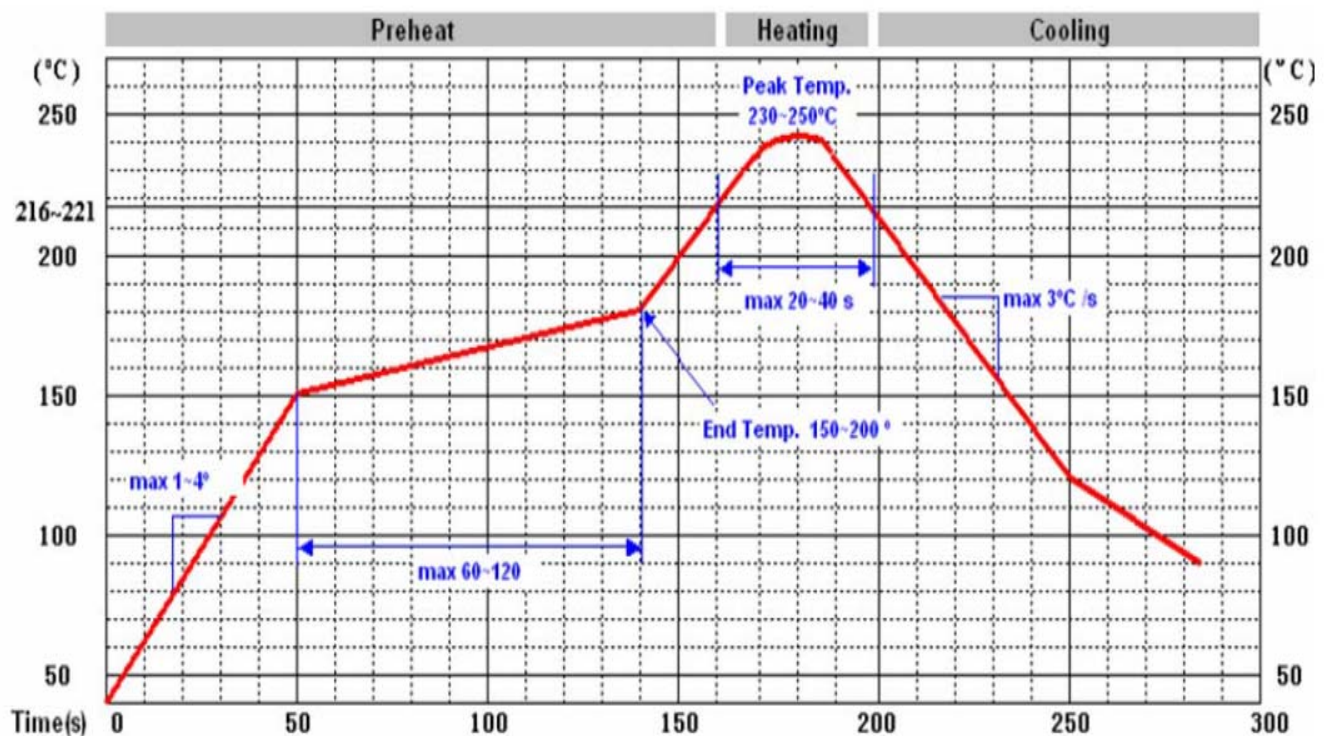

**Note:** The final soldering temperature chosen at the factory depends on additional external factors like choice of soldering paste, size, thickness and properties of the baseboard, etc. Exceeding the maximum soldering temperature in the recommended soldering profile may permanently damage the module.

©Copyright2014SKYTOP WirelessTECHNOLOGYCO.,LTD.AllRightReservd

The information contained herein is subject to change without notice.

**Skytop Wireless Technology Co. , LTD**

Add:No.257 LiangJi Building East Central Road,LongHua district Shenzhen city

Phone: 86-755-89580865

fax: 86-755-89580855

N 22° 32' 17", E 114° 07' 07"

<http://www.skytoprf.com>

Not to be reproduced in whole or part for any purpose without written permission of skytop Technology Inc ('skytop'). Information provided by skytop is believed to be accurate and reliable. These materials are provided by skytop as a service to its customers and may be used for informational purposes only. skytop assumes no responsibility for errors or omissions in these materials, nor for its use. skytop reserves the right to change specification at any time without notice.

These materials are provides 'as is' without warranty of any kind, either expressed or implied, relating to sale and/or use of skytop products including liability or warranties relating to fitness for a particular purpose, consequential or incidental damages, merchantability, or infringement of any patent, copyright or other intellectual property right. skytop further does not warrant the accuracy or completeness of the information, text, graphics or other items contained within these materials. skytop shall not be liable for any special, indirect, incidental, or consequential damages, including without limitation, lost revenues or lost profits, which may result from the use of these materials.

skytop products are not intended for use in medical, life-support devices, or applications involving potential risk of death, personal injury, or severe property damage in case of failure of the product.